

YOUR PARTNER WORLDWIDE



HSL-15 / HSL-2

Portable High-Speed Gate Valve Grinder
for the repair of sealing surfaces of gate valves and wedges

HSL-15 DN 175-400 mm (DN 7"-16")

HSL-2 DN 200-600 mm (DN 8"-24")

Huge time savings
up to 90% !



Patent pending

THE PREMIUM-PRODUCTS – MADE BY EFCO – MADE IN GERMANY

Our machines represent the latest technology in valve repair and set standards

- Very high speed of the **mechanically driven grinding spindles** simultaneously to slow rotation of planet disc
- High grinding speed:..... up to 21 m/s
- Very high removal rate:..... up to 2 mm/h (grinding „Stellite 6 / 21“ Ø 350/325 mm)
- Grinding spindles with CBN-coating by standard
- Machining „Stellite 6 / 21“ using driven CBN-grinding spindles, compared to removal rate with:
 - non-driven CBN-grinding spindles:..... 8 – 10 times higher
 - non-driven grinding spindles with folio or paper abrasives:...40 – 50 times higher

The modular design of the HSL-15

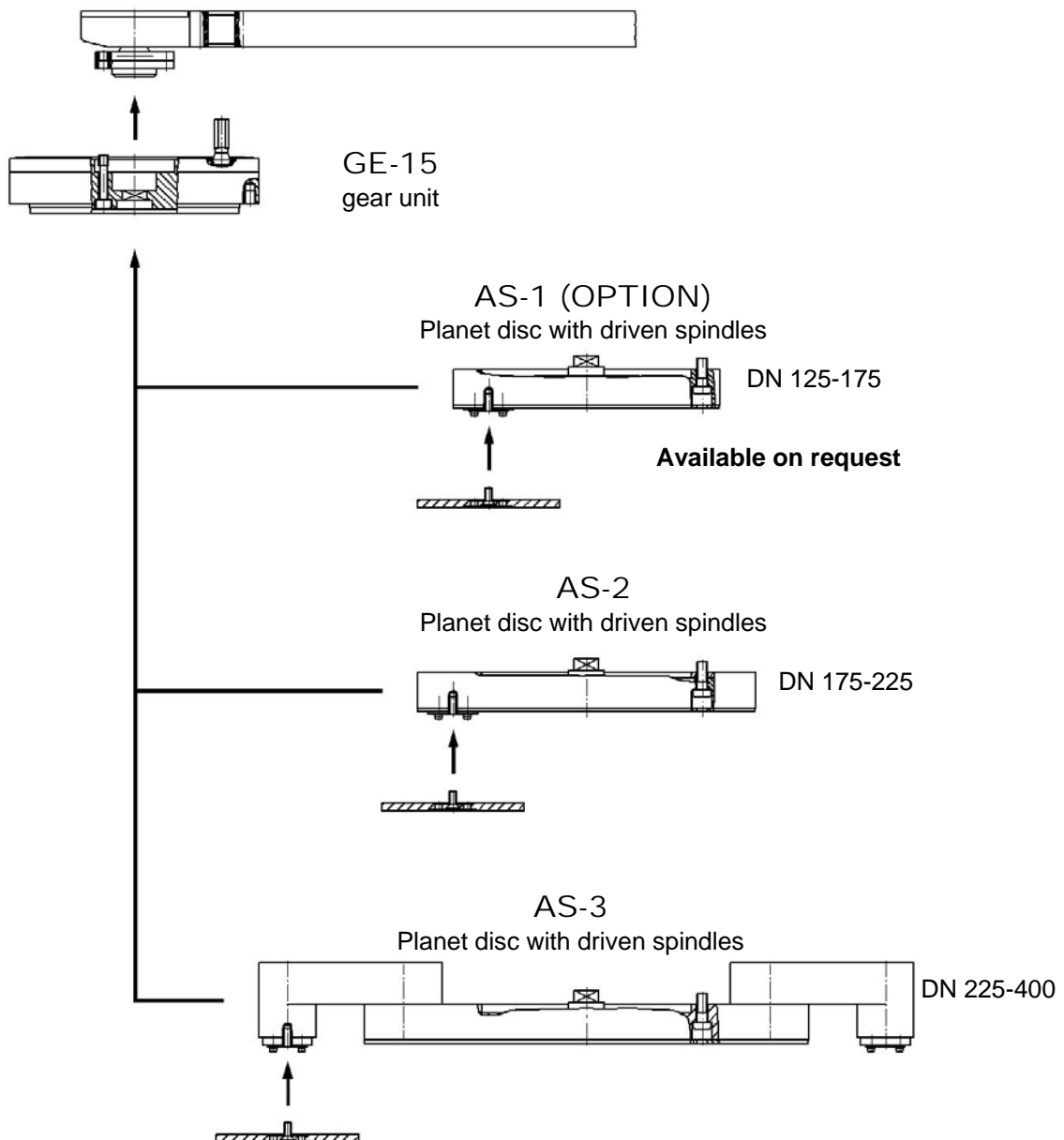

The modular design of the HSL-2

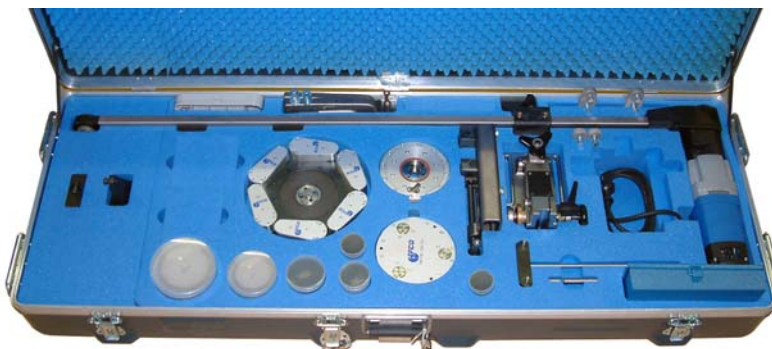
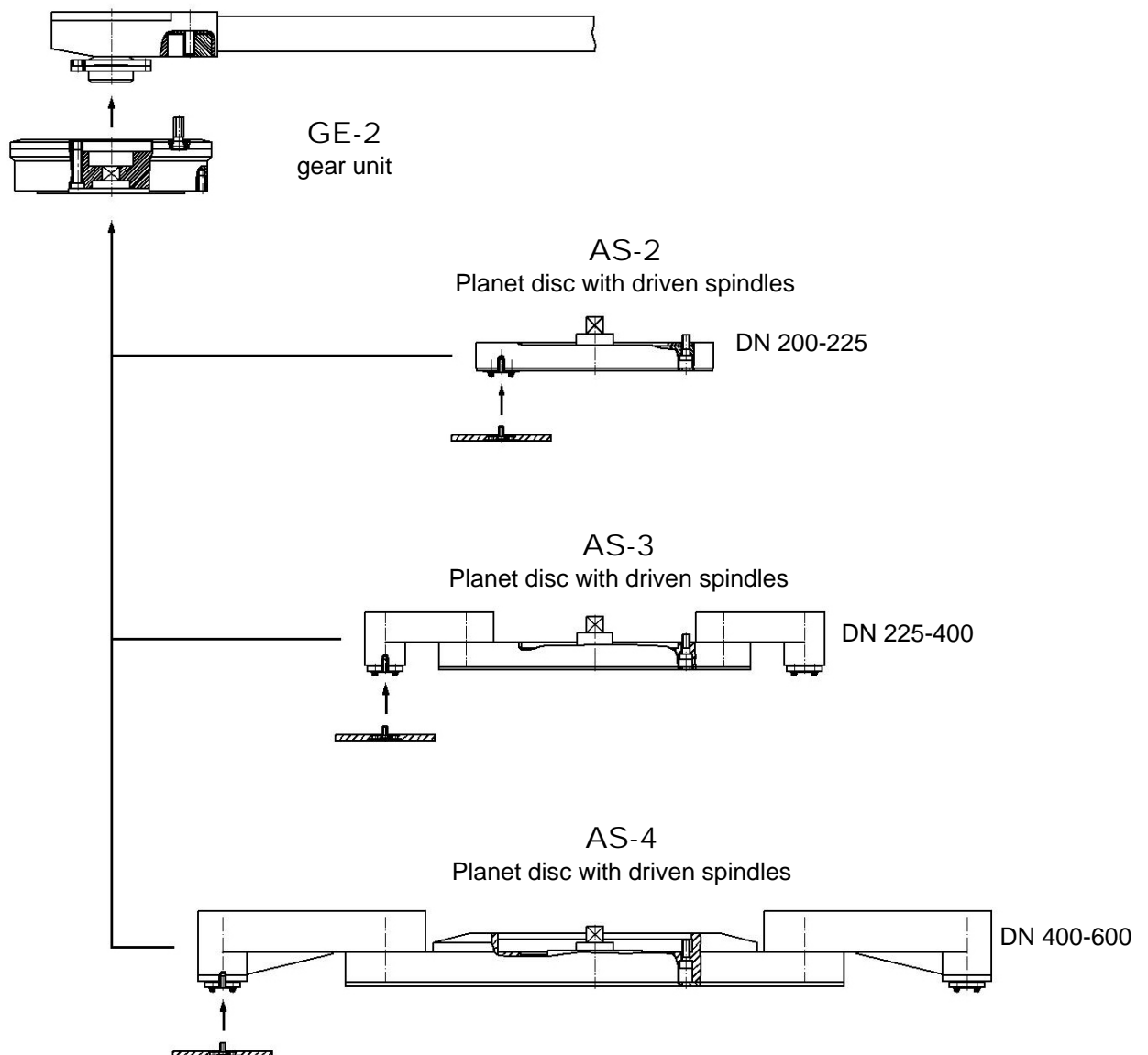

The EFCO HSL-Machines, -like all other EFCO products-, are a complete repair system, designed for on-site or in-shop use.

Each complete machine including all accessories is delivered in a plastic transport case.

← Example of a case

Technical Details HSL

- Working range:
 - HSL-15** with GE-15:
 - AS-1 : DN 125-175 (DN 5"-7") (OPTION)
 - AS-2 : DN 175-225 (DN 7"-9")
 - AS-3 : DN 225-400 (DN 9"-16")
 - HSL- 2** with GE-2:
 - AS-2 : DN 200-225 (DN 8"-9")
 - AS-3 : DN 225-400 (DN 9"-16")
 - AS-4 : DN 400-600 (DN 16"-24")

- Height H:
 - Planet disc AS-1 + GE-15: 81,5 mm (OPTION)
 - Planet disc AS-2 + GE-15: 77,5 mm
 - Planet disc AS-3 + GE-15: 77,5 mm
 - Planet disc AS-2 + GE-2 : 105 mm
 - Planet disc AS-3 + GE-2 : 105 mm
 - Planet disc AS-4 + GE-2 : 110 mm

Outer grinding diameter A (mm) when using grinding spindle of diameter D (mm)														
	Ø40		Ø50		Ø60		Ø80		Ø90		Ø100		Ø120	
	min.	max.	min.	max.	min.	max.	min.	max.	min.	max.	min.	max.	min.	max.
AS-1 OPTION	-	153	-	163	-	173	-	193	-	203	-	-	-	-
AS-2	-	194	-	204	-	214	-	234	-	244	-	254	-	274
AS-3	242	376	252	386	262	396	282	416	292	426	302	436	322	456
AS-4	405	637	415	647	425	657	445	677	455	687	465	697	485	717

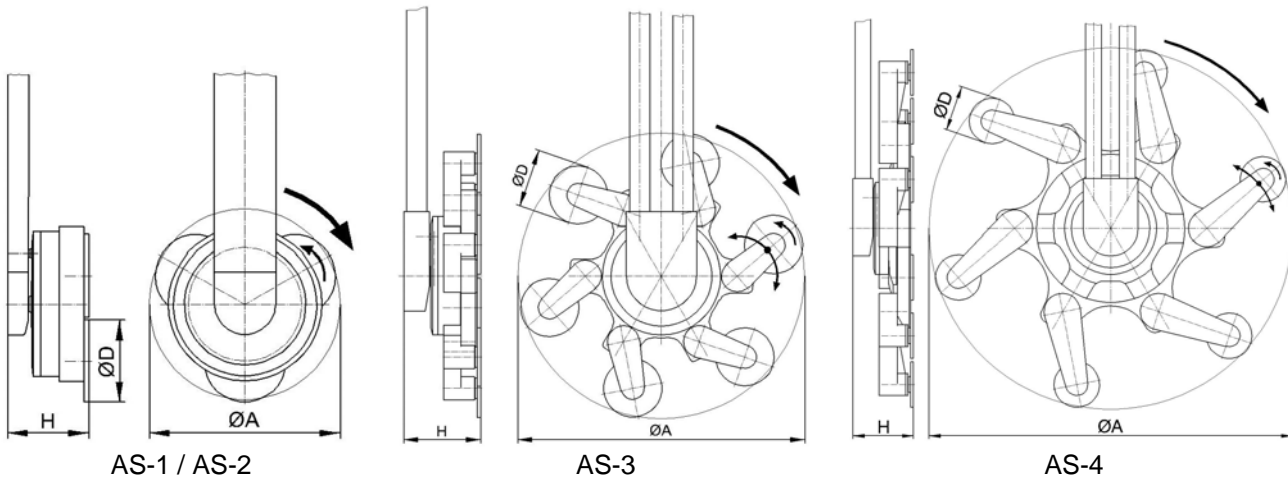

Subject to technical change.

Parent company:
 EFCO-Maschinenbau GmbH & Co. KG
 Otto-Brenner-Straße 5-7
 52353 Düren / Germany
 Phone: +49-2421 / 989-0
 Fax: +49-2421 / 86260
 e-mail: info@efco-dueren.com



Agencies in many countries
www.efco-dueren.com

EFCO-USA, Inc.
 1611 Telegraph Ave., Suite 1600
 Oakland, CA 94612
 Phone: (510)-272-0481
 (800) EFCO-USA
 Fax: (510)-272-0483
 e-mail: sales@efcousa.com



VALVE REPAIR AND TESTING EQUIPMENT
 THE PREMIUM-PRODUCTS – MADE BY EFCO – MADE IN GERMANY