

VSK

Special tools for grinding conical valve seats

8-300 mm (1/4-12") dia.

VSK tools facilitate the quick repair of conical sealing faces on all shut-off and control valves with nominal diameter 8-300 mm.

VSK tools prove their strength everywhere where fast valve repair and economy are required:

- **Wide-ranging use:**
in conventional power stations, nuclear power stations, refurbishment companies, refineries, chemical plant, shipyards, sugar mills, paper mills, on ships, by valve manufacturers and many others.
- **Long life due to the use of:**
 - high-quality materials
 - powerful drives
 - wear-resistant tools
 - stable light-weight design
- **Use independent of:**
 - width and hardness of sealing faces to be machined
 - installation position of fitting (horizontal, vertical)
 - type of fitting
- **Due to its low weight**
 - easy handling
 - hand-held operation
 - fast setting up

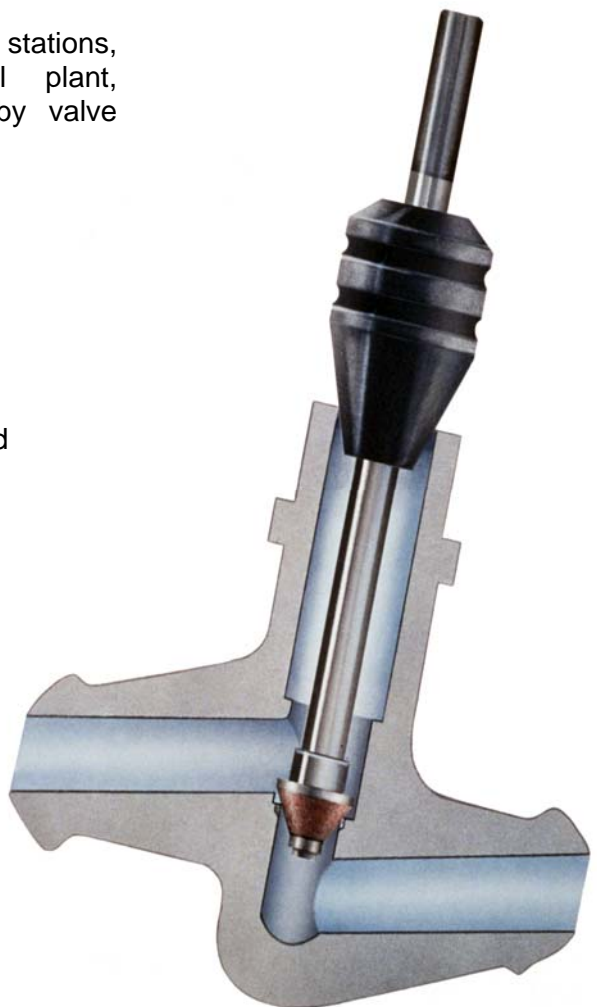

EFCO VSK Tools An impressive Concept

- Simple handling
- Low weight
- One-man operation
- Wear-resistant tools
- Good price/performance ratio
- High profitability and efficiency
- Optimum material removal due to use of high-quality abrasives
- Simple fitting of tools
- Safe centring using centring cone or rim chuck, thus centred machining
- Hard grinding cones to which the abrasive is attached ensure precise angular geometry

VSK Specifications

	VSK-05	VSK-1	VSK-2	VSK-3	VSK-4	VSK-5
DN (mm)	8-32 1/4"-1 1/4"	8-50 1/4"-2"	8-65 1/4"-2.5"	8-100 1/4"-4"	8-150 1/4"-6"	80-300 3"-12"
Drive	electric 230/110 V, 50/60Hz or pneumatic 6-7 bar					
Standard seating angle	30° (2x15°), 40° (2x20°), 60° (2x30°), 75 (2x37.5), 90° (2x45°) (other angles on request)					

Standard seating angle

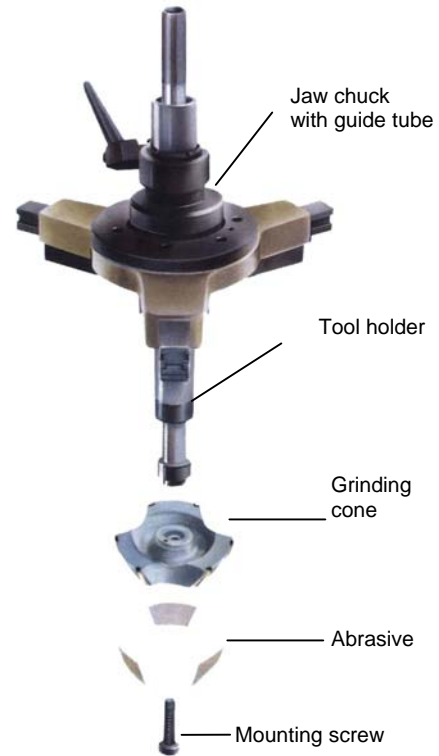
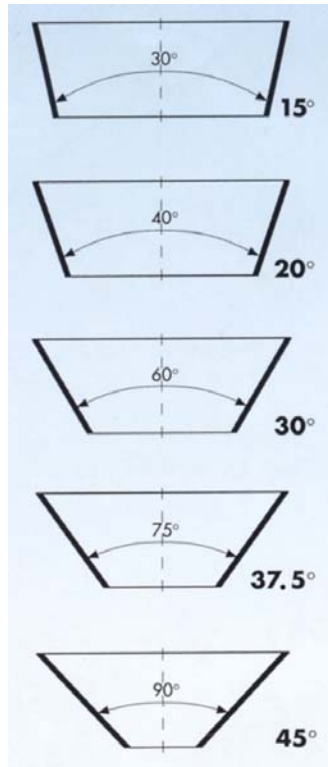
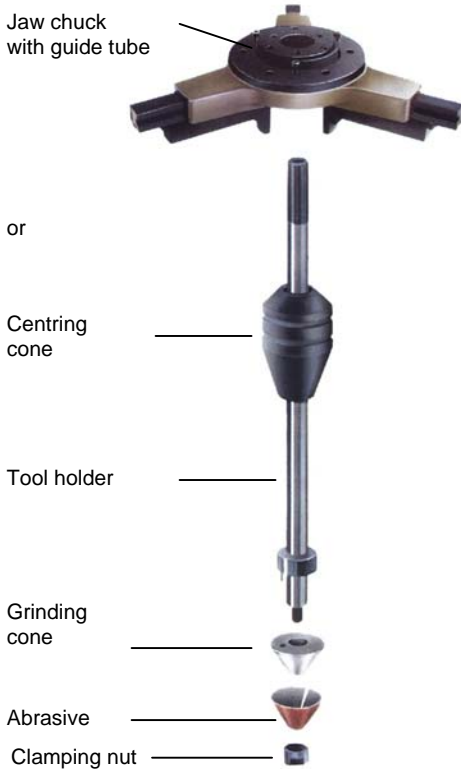

The EFCO VSK tools, as do all EFCO products, provide a complete repair system.

It is possible to combine various angles and sizes into a complete tool set as per your specification.

Subject to technical change.

Parent company:

EFCO-Maschinenbau GmbH & Co. KG
 Otto-Brenner-Straße 5-7
 52353 Düren / Germany
 Phone: +49-2421 / 989-0
 Fax: +49-2421 / 86260
 e-mail: info@efco-dueren.com



Agencies in many countries
www.efco-dueren.com

EFCO-USA, Inc.
 1611 Telegraph Ave., Suite 1600
 Oakland, CA 94612
 Phone: (510)-272-0481
 (800) EFCO-USA
 Fax: (510)-272-0483
 e-mail: sales@efcousa.com



VALVE REPAIR AND TESTING EQUIPMENT
 THE PREMIUM-PRODUCTS – MADE BY EFCO – MADE IN GERMANY